

M101 SERIES BABY SCALES



Feature:

- Removable baby tray, when the baby grew up, can take stand on weighing scale.
- Drinking function (weighing before and after baby drinking)
- Adjustable 4 feet.
 1. Removable tray enables use as a scale for small children as well
 2. Wall mount for the display device
- Optional initial-verification.
- Optional RS-232 can connect to computer, LP-50 label printer or TPuP mini printer.

Options:

- Optional RS-232, can connect computer and printer.



M101 SERIES BABY SCALES

Specification:

Model	M101
Display	25mm digit LCD display, with white LED backlight
Capacity	6kg/15kg
Height measuring	Approx. 400mm to 800mm
Pan size	600x250mm
Platform size	280x325mm
Keyboard	7 keys(Membrane switch)
Housing	ABS plastic
Max. Divisions	2X3,000e
ADC	Sigma delta
ADC update	update≤1/10 second
Operate Temp	-10°C~+40°C
Power	2000mAh Ni-MH battery package(optional, size AA),external AC power adapter
Gross Weight	5.5kg
Packing	Master carton 4in 1, gross weight 24.6kg, dimension 0.36m ³

Dimension(mm):

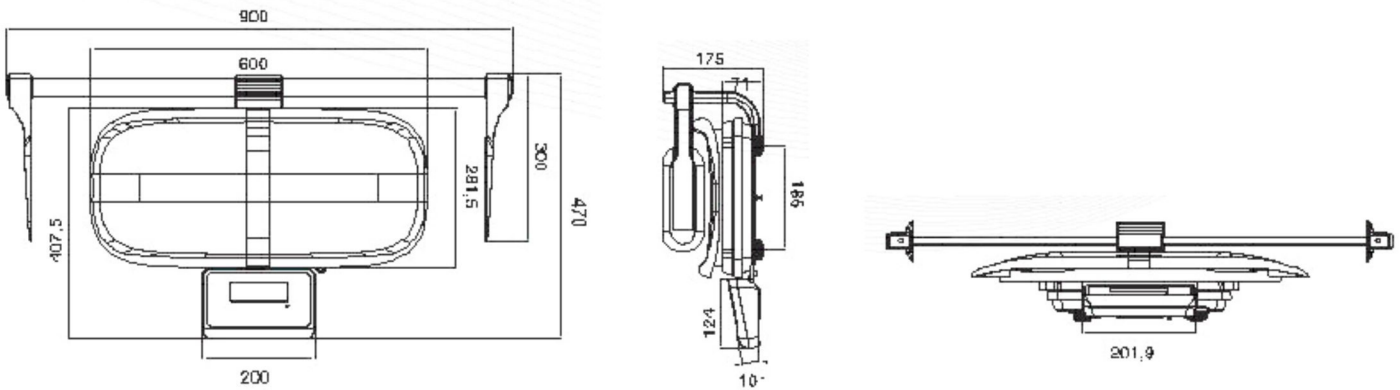

We Represent



Intertek

014

AL HINAI NATIONAL ENTERPRISES LLC

Po Box: 836, PC: 132, Al-Khoudh, Sultanate of Oman

Tel: +968 24423409 | Fax: +968 24423449

E-Mail: endeloman@omanweighing.com | Web: www.omanweighing.com